

### Reset circuit

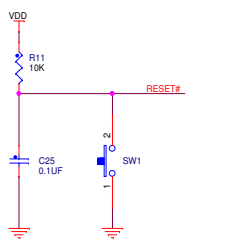

### Oscillator options

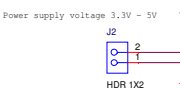
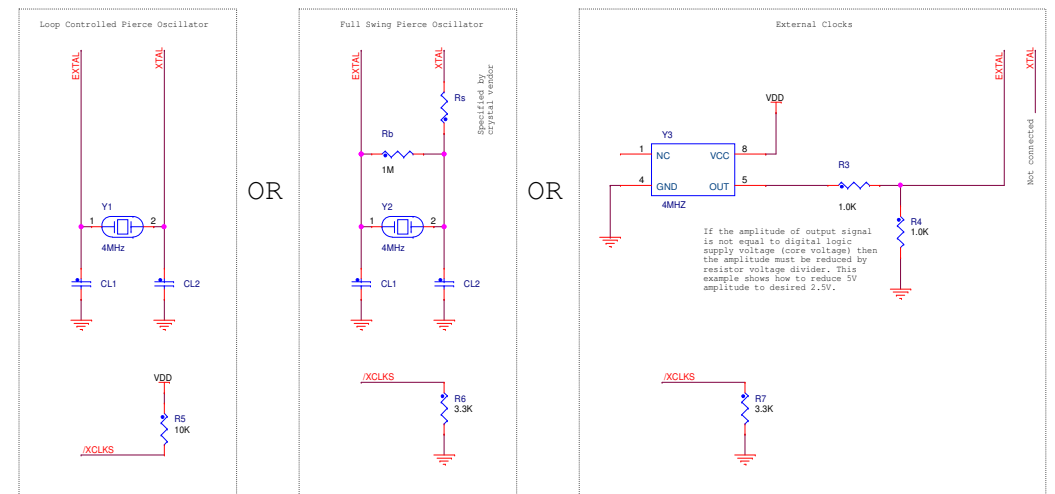

		<b>Freescale Semiconductor RCSC</b> 1. maja 1009 765 61 Roznov p. R. Czech republic, Europe		
		This document contains information proprietary to Freescale Semiconductor and shall not be used for engineering design, procurement or manufacture in whole or in part without the express written permission of Freescale Semiconductor.		
Designer: <Designer>	Drawing Title: <Title>	ICAP Classification: FCP:	FIUC: X	PUBI:
Drawn by: <DrawBy>	Page Title: <PageTitle>	Size C	Document Number SCH-XXXXX PDF: SPF-XXXXX	Rev X
Approved: <Approver>	Date: Monday, April 23, 2012	Sheet 1	of 1	