



Automotive Math and Motor Control Library (AMMCLib)

AMMCLIB

Last Updated: Apr 9, 2024

The Automotive Math and Motor Control Library (AMMCLib) set provides essential building blocks for rapid development of automotive embedded applications with high-performance arithmetic, trigonometric, digital signal processing and math functions. The AMMCLib is available as a production-ready precompiled or source code package.

A significant portion of the AMMCLib supports both sensor-based and sensorless motor control applications; it also assists with fixed-point fractional 16/32-bit and single-precision floating-point arithmetic. All AMMCLib functions come with MATLAB® and Simulink® bit-accurate models for model-based design, simulation and code generation supporting Embedded Coder®.

Auto AMMCLIB General Architecture Block Diagram

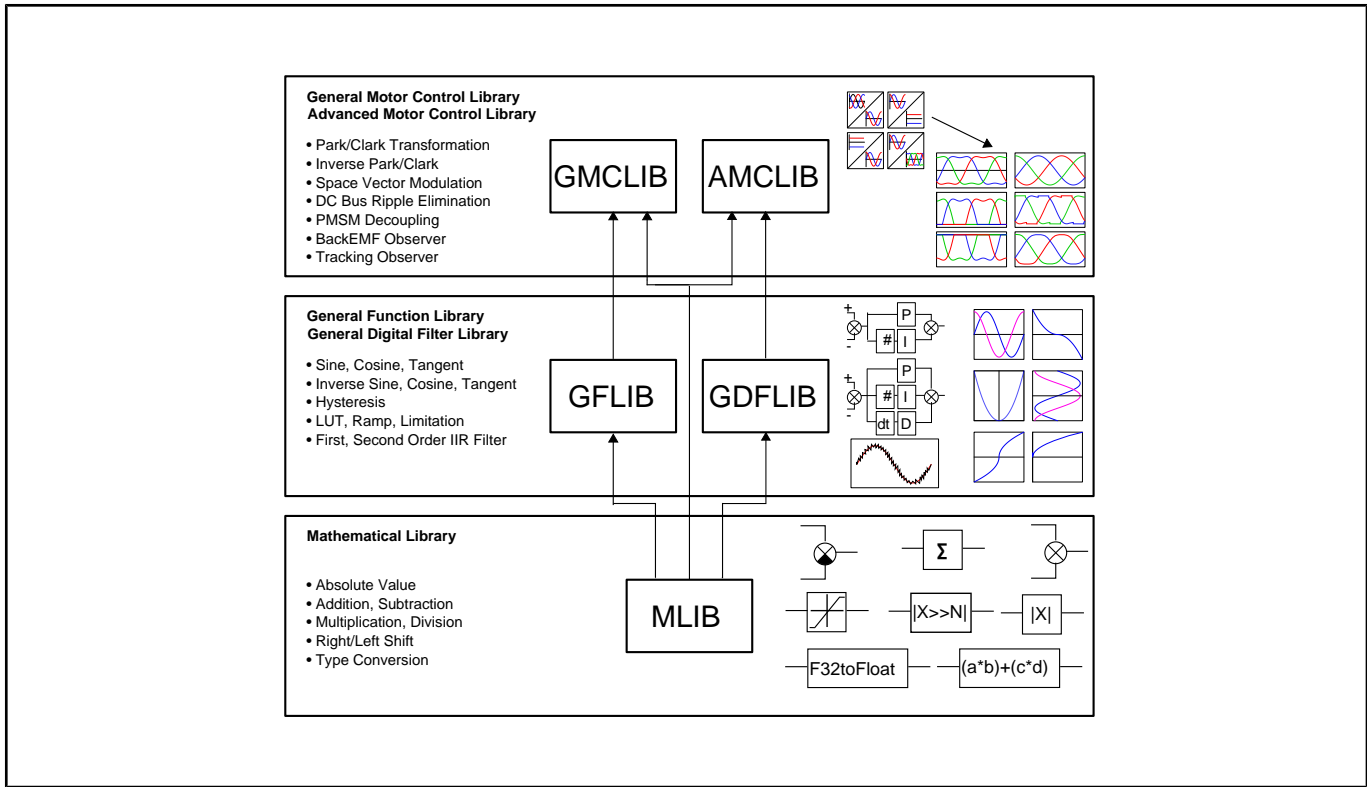

Auto AMMCLIB Architecture for KEA Block Diagram

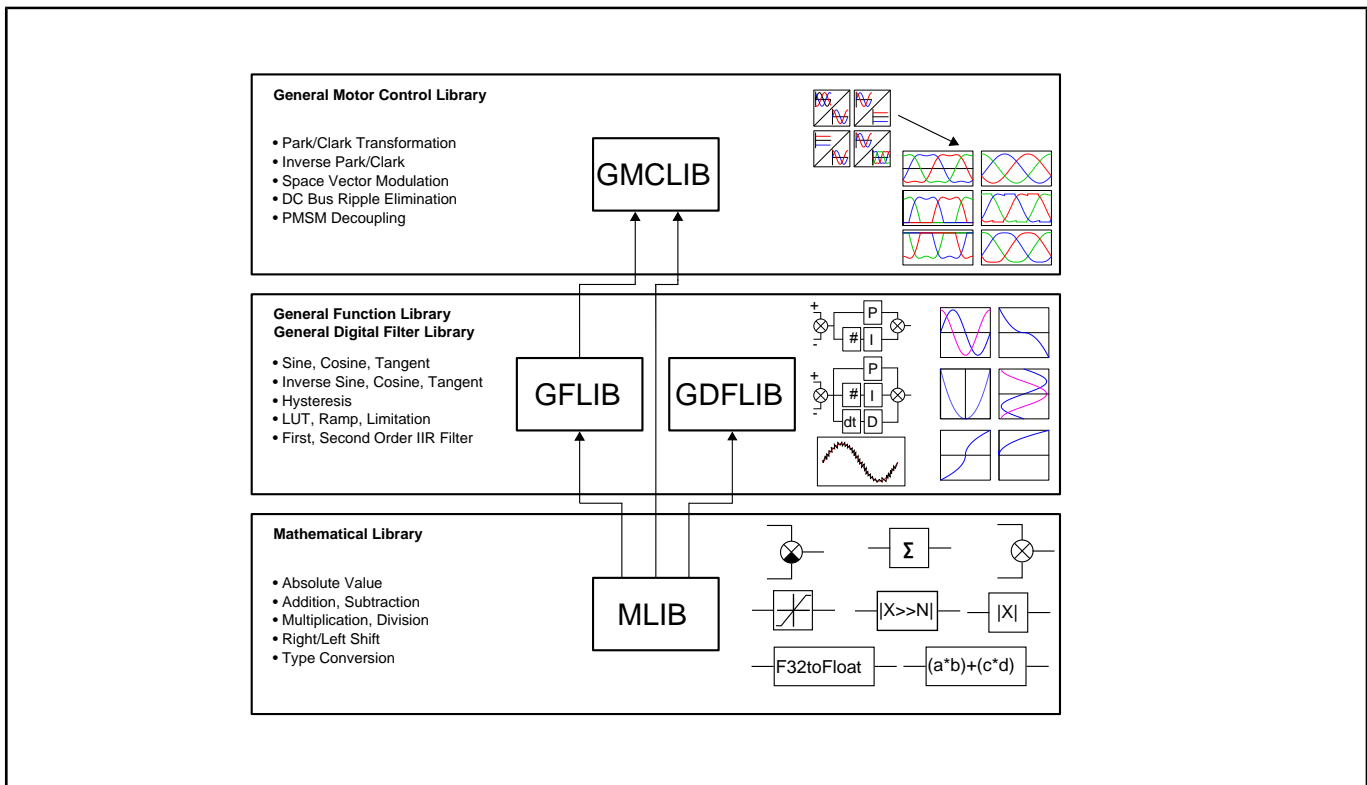

Auto AMMCLIB Architecture for S32Z/E and S32V Block Diagram

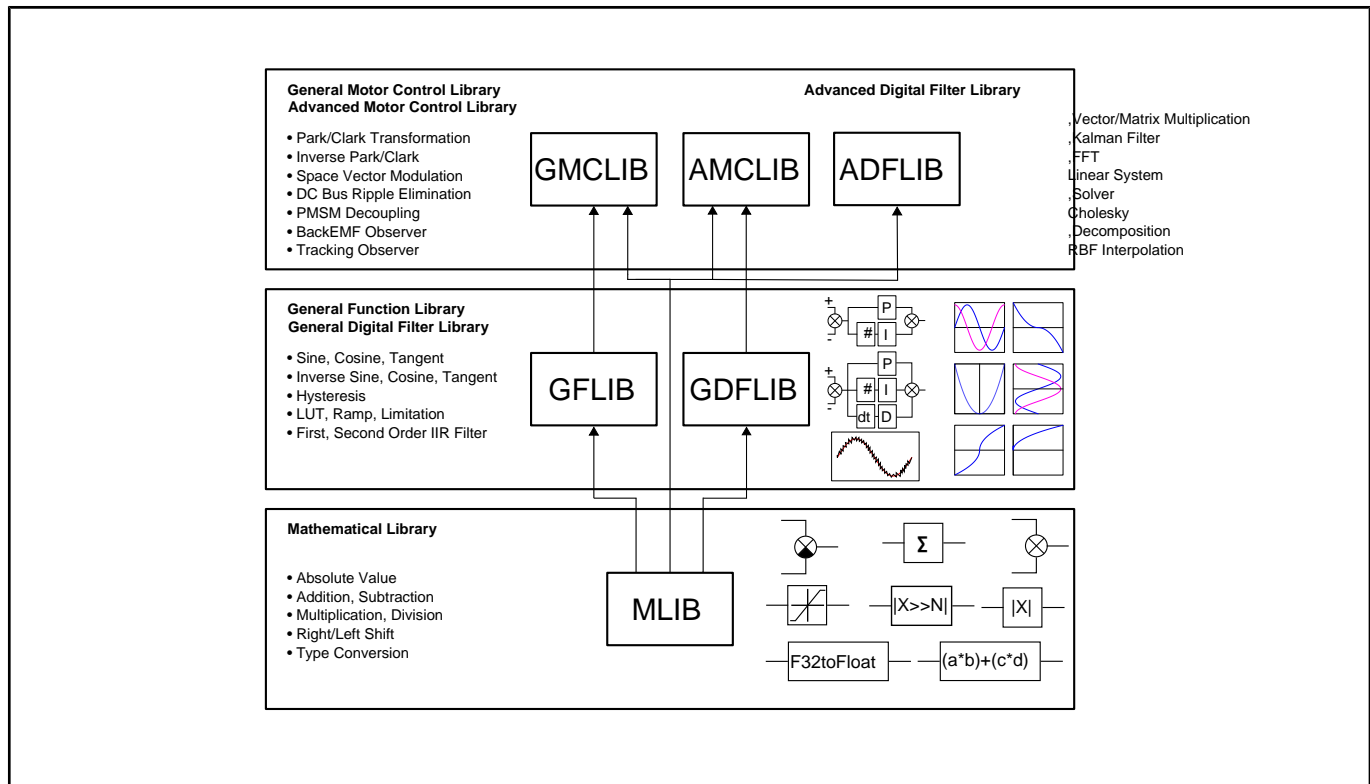

Automotive software General Block Diagram Block Diagram

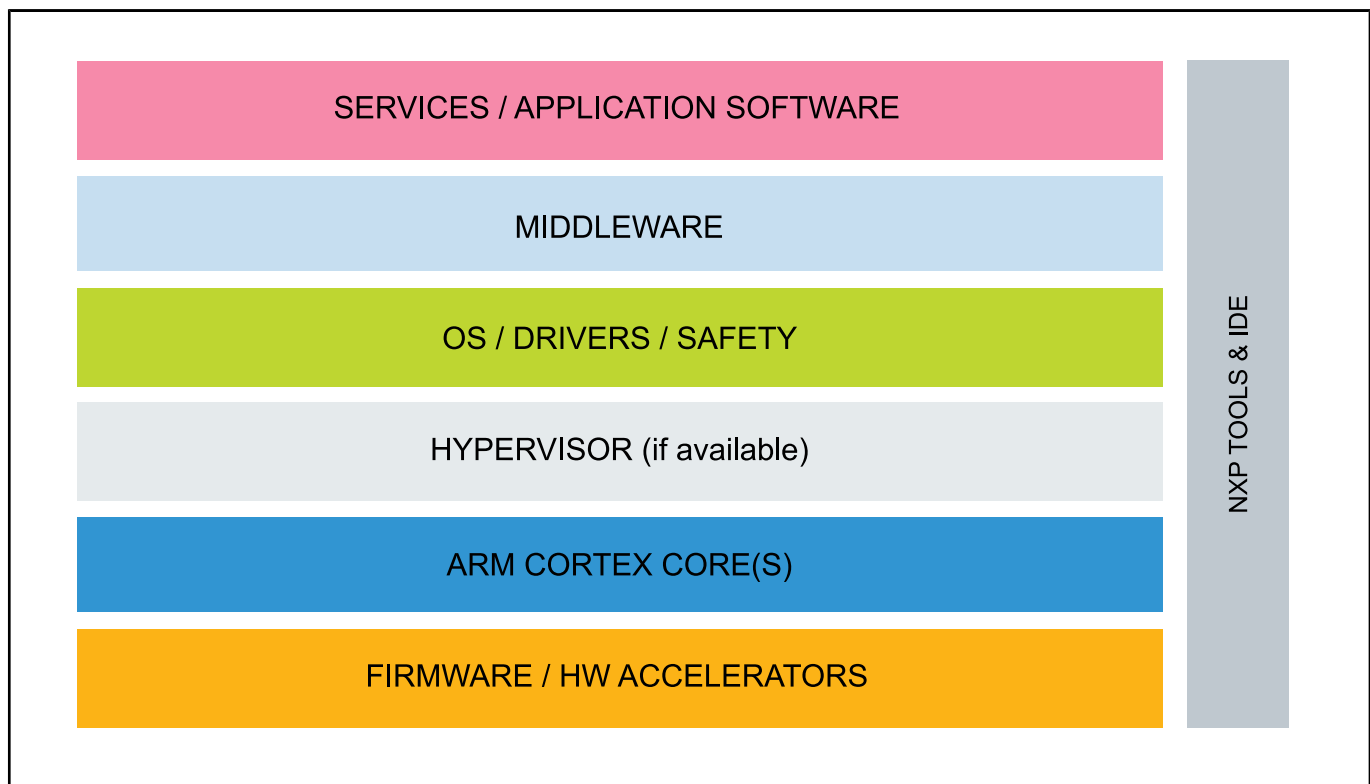

View additional information for [Automotive Math and Motor Control Library \(AMMCLib\)](#).

Note: The information on this document is subject to change without notice.

www.nxp.com

NXP and the NXP logo are trademarks of NXP B.V. All other product or service names are the property of their respective owners. The related technology may be protected by any or all of patents, copyrights, designs and trade secrets. All rights reserved. © 2024 NXP B.V.