



PSI5 Automotive Safety Digital Accelerometer

FXLS93

Last Updated: Sep 19, 2023

The FXLS93 family is the latest generation of airbag crash sensors from NXP. The devices are designed using NXP proprietary UMEMS sensing technology combined together with a signal conditioning ASIC in a QFN 4 x 4 x 1.45 mm package.

The devices feature a user PSI5 interface. They can measure acceleration in single or dual independent axis configuration from +/-15.5 g to +/-500 g. The embedded DSP provides fully programmable digital high and low pass filtering.

The FXLS93 family is fully AEC-Q100 qualified up to 125°C operating temperature and is compliant with the AK LV 27 requirements. The package has wettable flanks for solder joint inspection. FXLS93 products have been developed following ISO26262 2018 edition and can be used in up to ASIL D system.

For additional information and sample availability, contact your local [sales office](#).

FXSL9x Single Axis internal Block Diagram Block Diagram

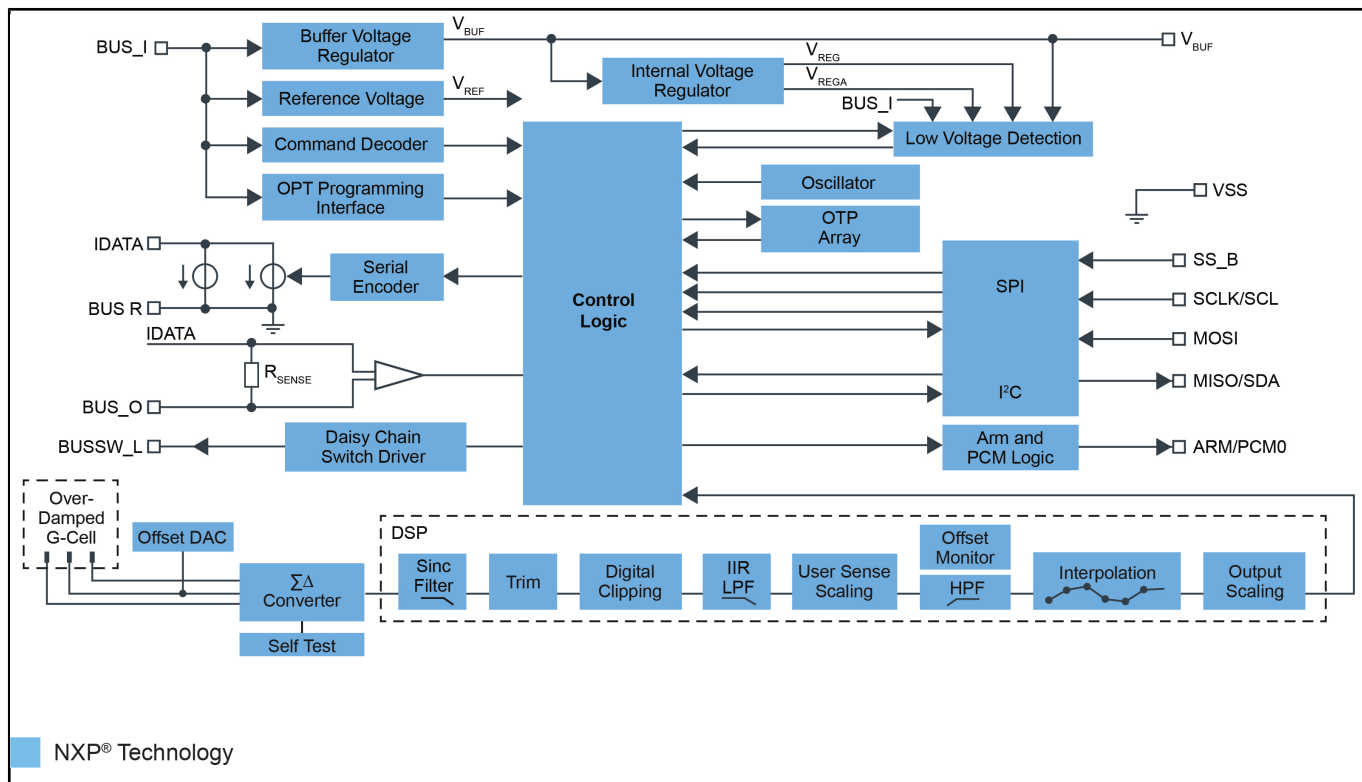

FXLS93 PSI5 Application Diagram Block Diagram

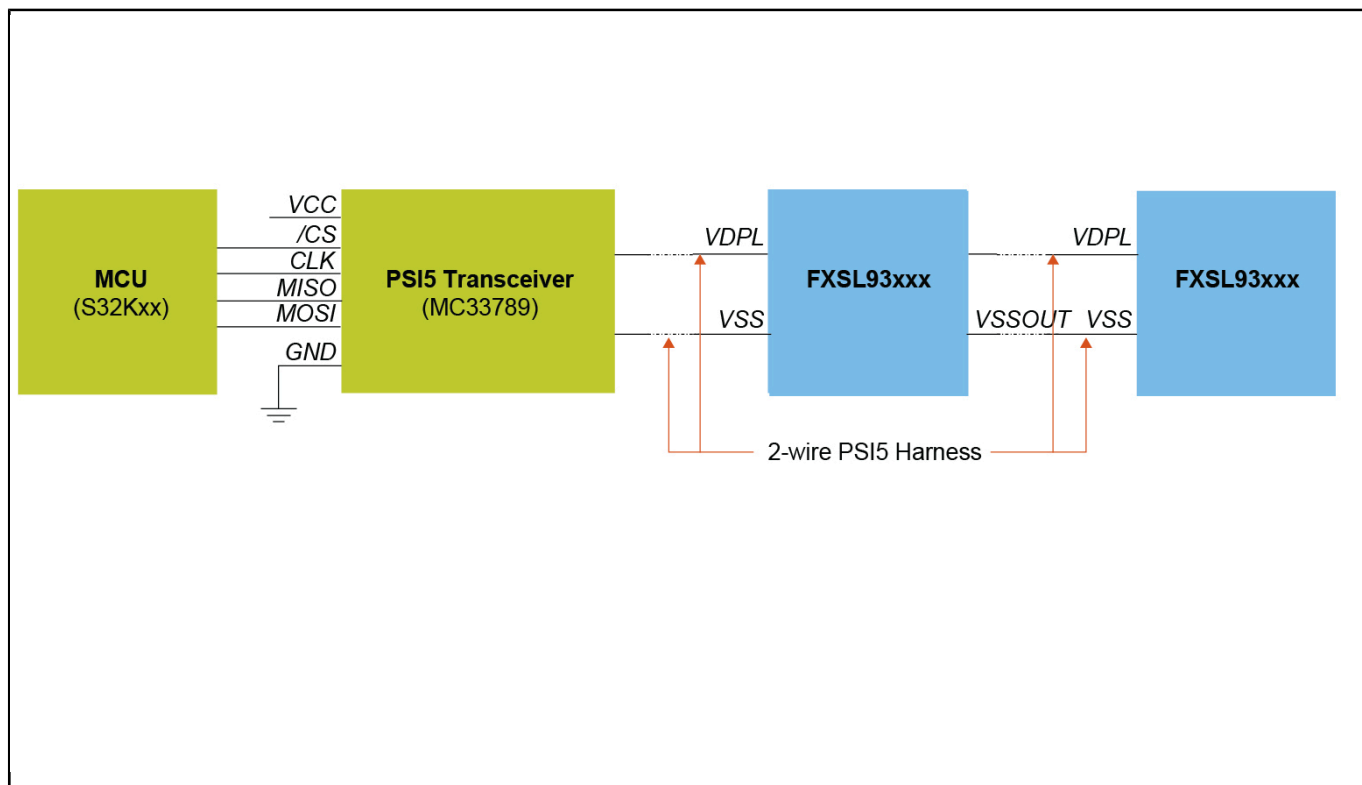

View additional information for [PSI5 Automotive Safety Digital Accelerometer](#).

Note: The information on this document is subject to change without notice.

www.nxp.com

NXP and the NXP logo are trademarks of NXP B.V. All other product or service names are the property of their respective owners. The related technology may be protected by any or all of patents, copyrights, designs and trade secrets. All rights reserved. © 2024 NXP B.V.