



# Ultra-Reliable MPC5777M MCU for Automotive and Industrial Engine Management

## MPC5777M

Last Updated: May 26, 2023

The MPC5777M Power Architecture® MCU targets high-end industrial and powertrain applications that meet next-generation advanced engine control, functional safety, and security requirements.

- Provides task flexibility and parallel processing by leveraging the I/O processor to offload computational cores
- Deters software hacking and aftermarket tuning (which affects unauthorized warranty returns) with next-generation security protection
- Comprehensive development tools simplify and accelerate system design

# MPC5777M 32-bit Multicore MCU for Powertrain Block diagram. Block Diagram

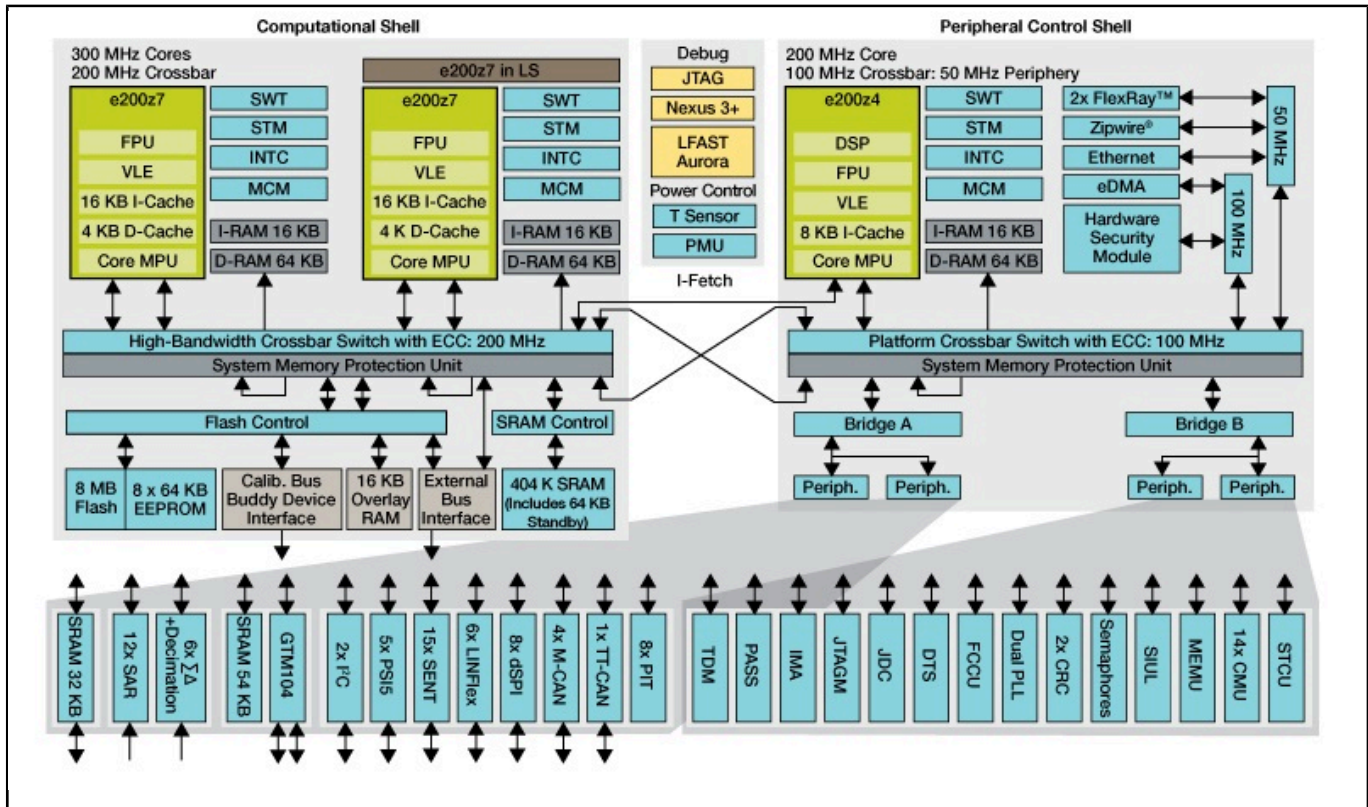

View additional information for [Ultra-Reliable MPC5777M MCU for Automotive and Industrial Engine Management](#).

Note: The information on this document is subject to change without notice.

[www.nxp.com](http://www.nxp.com)

NXP and the NXP logo are trademarks of NXP B.V. All other product or service names are the property of their respective owners. The related technology may be protected by any or all of patents, copyrights, designs and trade secrets. All rights reserved. © 2024 NXP B.V.