



5 Watt Wireless Charging Transmitter ICs for Automotive Applications

MWCT1x0xA

Not Recommended for New Designs

Recommended to use: [MWCT2xx3A](#)

Last Updated: Jan 10, 2024

The NXP® MWCT1001A and MWCT1003A multi-coil wireless charging transmitter ICs provide complete controller functionality to implement a wireless charging transmitter solution in an automotive environment.

- Implement and control the power transfer function, as well as monitor and manage overall system state, such as foreign object detection, temperature and system efficiency
- Standard and premium solutions provide scalability, differentiation and a fully functional, industry compliant system solution
- NXP offers an upgrade path to the WCT1003A, providing additional hardware and software resources to customize the application and maximize differentiation

MWCT1XXXA Block diagram Block Diagram

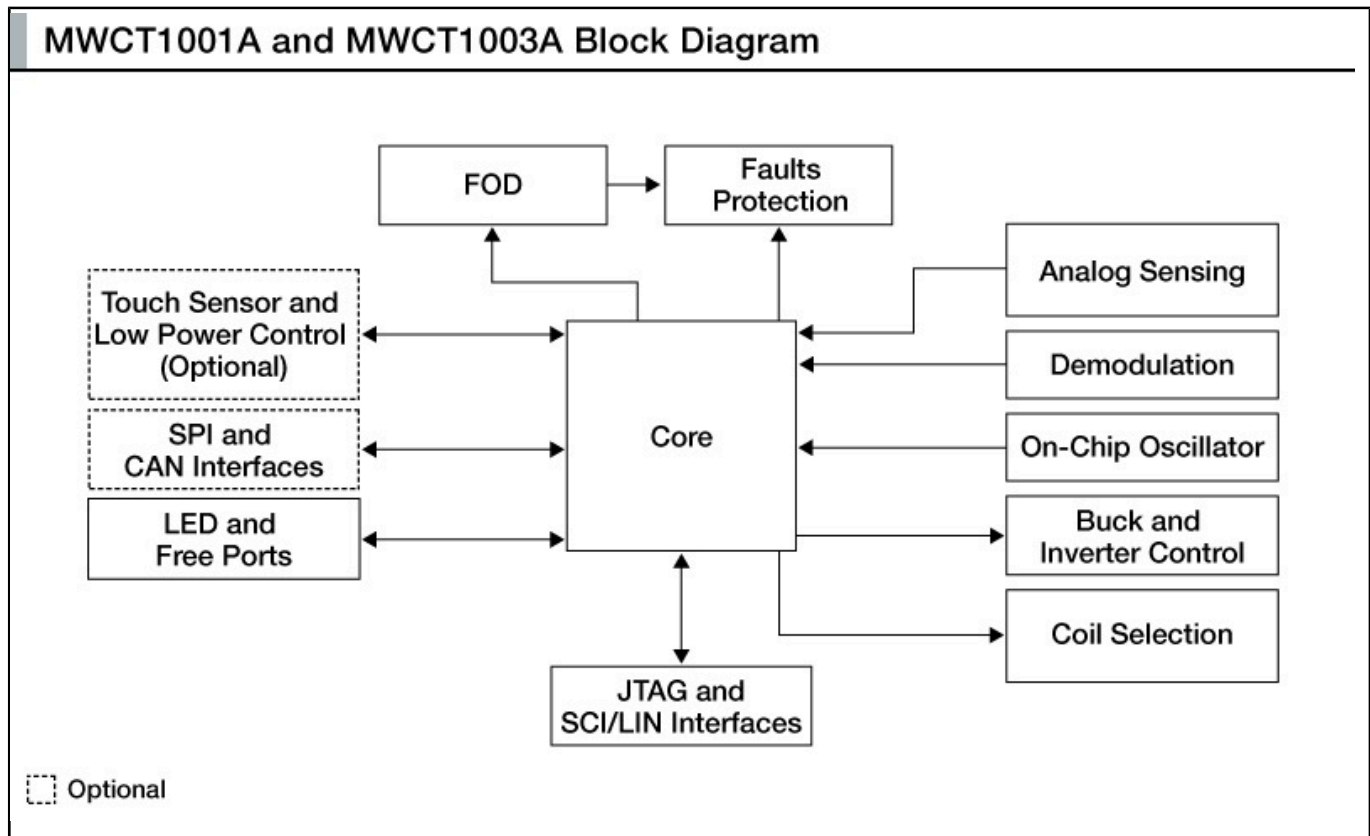

View additional information for [5 Watt Wireless Charging Transmitter ICs for Automotive Applications](#).

Note: The information on this document is subject to change without notice.

www.nxp.com

NXP and the NXP logo are trademarks of NXP B.V. All other product or service names are the property of their respective owners. The related technology may be protected by any or all of patents, copyrights, designs and trade secrets. All rights reserved. © 2024 NXP B.V.