



One-Chip 5 V Qi Wireless Transmitter

NXQ1TXX5

Not Recommended for New Designs

This product is Not Recommended for New Designs. Please visit our [Wireless Power Portfolio](#) for more options.

Last Updated: May 24, 2022

The NXQ1TXH5 is a fully integrated one-chip controller and driver IC enabling the design of a 5 V Qi-certified low-power wireless charger. It includes a 5 V full-bridge power stage, as defined in the Wireless Power Consortium (WPC) low power Qi configurations A5, A11, A12 and A16. The device is optimized for minimum external component count, enabling a very low cost application and a simple PCB design.

The NXQ1TXH5 uses dedicated analog ping circuitry to detect devices, according to the Qi standard, achieving a very low standby power consumption of 10 mW. The NXQ1TXH5 takes care of a reliable ASK communication and controls the wireless power transfer from the transmitter to the receiver, while monitoring for fault conditions such as overheating or interference by metal objects. The device is optimized to operate from a USB power supply and uses Smart Power Limiting (SPL) to adjust the output power automatically to compensate for power-limited supplies. The device supports Foreign Object Detection (FOD), and operates according to the WPC Qi low power V1.2 specifications.

LED and buzzer outputs are available for the user interface. For the LED outputs a wide range of blinking modes can be selected in the application. Static Power Reduction (SPR) allows multiple NXQ1TXH5-based transmitters to operate from a single USB power supply by limiting power consumption per device.

The NXQ1TXH5 comes in a size optimized low cost 5 mm × 5 mm, 32-pin HVQFN package.

NXQ1TXL5 Block Diagram Block Diagram

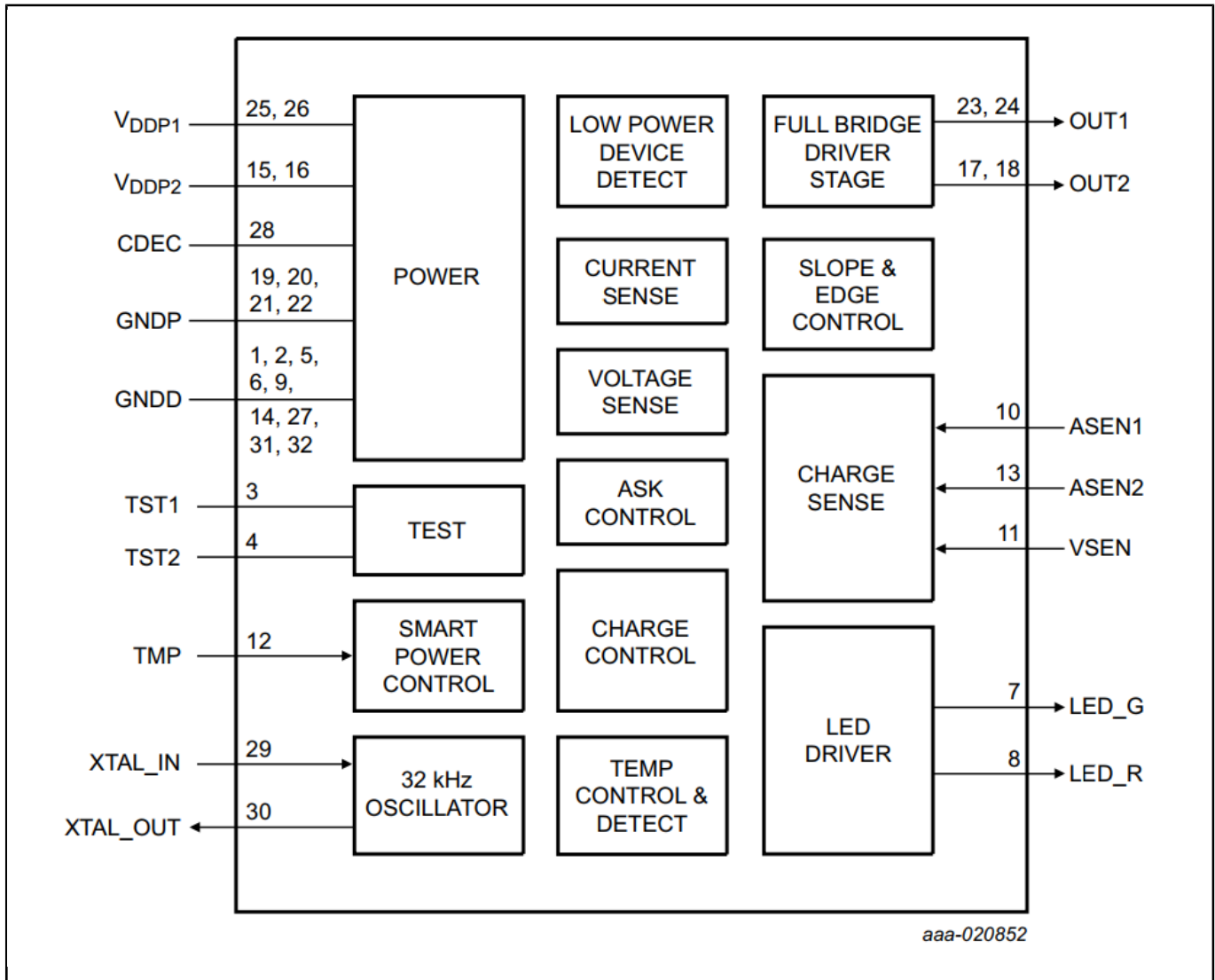

View additional information for [One-Chip 5 V Qi Wireless Transmitter](#).

Note: The information on this document is subject to change without notice.

www.nxp.com

NXP and the NXP logo are trademarks of NXP B.V. All other product or service names are the property of their respective owners. The related technology may be protected by any or all of patents, copyrights, designs and trade secrets. All rights reserved. © 2024 NXP B.V.