



60 X 8 LCD High-Drive Segment Driver for Automotive and Industrial

PCA9620

Last Updated: Nov 9, 2023

The PCA9620 is a peripheral device which interfaces to almost any Liquid Crystal Display (LCD) with low multiplex rates. It generates the drive signals for any static or multiplexed LCD containing up to eight backplanes, 60 segments, and up to 480 elements. The PCA9620 is compatible with most microprocessors or microcontrollers and communicates via a two-line bidirectional I²C-bus. Communication overheads are minimized using a display RAM with auto-incremented addressing and display memory switching. The PCA9620 features an internal charge pump with internal capacitors for on-chip generation of the LCD driving voltages.

PCA9620 Block Diagram

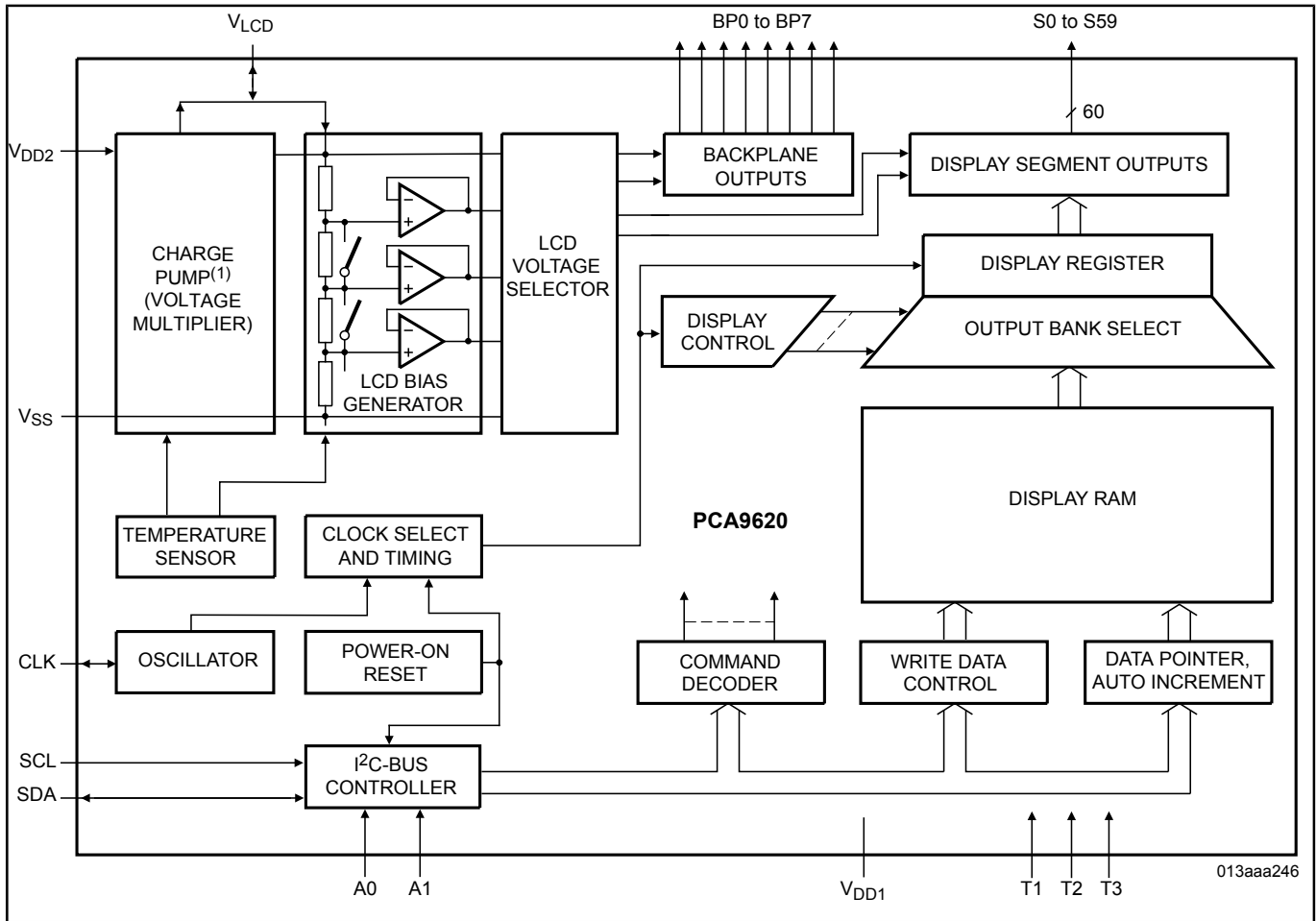

View additional information for [60 X 8 LCD High-Drive Segment Driver for Automotive and Industrial](#).

Note: The information on this document is subject to change without notice.

www.nxp.com

NXP and the NXP logo are trademarks of NXP B.V. All other product or service names are the property of their respective owners. The related technology may be protected by any or all of patents, copyrights, designs and trade secrets. All rights reserved. © 2024 NXP B.V.