

Design Recommendations to Implement Compatibility Between the MC13783VK and the MC13783VK5

by: Power Management and Audio Applications Team

1 Introduction

The MC13783VK and the MC13783VK5 are a power management and user interface (PMUI) integrated circuit that can be used in Freescale's 3G cellular platforms or other portable handheld applications such as non-3G protocol cellular, gaming devices, personal media players, remote controlled toys, etc.

The purpose of this application note is to provide the proper connections to ensure compatibility of the board between the MC13783VK and the MC13783VK5 parts.

2 Description

The differences between these two extensions is the manner of how the switcher parallel/single detection mechanism is realized. In the MC13783VK part, the mechanism is based on detection at power-up. The detection is based on the voltage level seen on the SWxBFB pin (x can be 1 or 2 symbolizing buck switcher1 or buck switcher2).

- If the level is 0 V, then single mode is detected.

Contents

1 Introduction	1
2 Description	1
3 Implementation of MC13783VK and MC13783VK5 Compatibility	2

- If the level is VATLAS, then the parallel mode is detected.

Where as in the MC13783VK5 part, the mechanism is based on continuous detection. The detection is based on the voltage level seen on different pins:

- Pin P11 named "RSVRD2 or SW1ABSPB" for buck switcher 1.
 - If the level is 0 V, then the parallel mode is detected.
 - If the level is 2.775 V, then the single mode is detected.
- Pin R12 named "RSVRD3 or SW2ABSPB" for buck switcher 2.
 - If the level is 0 V, then the parallel mode is detected.
 - If the level is 2.775 V, then the single mode is detected.

3 Implementation of MC13783VK and MC13783VK5 Compatibility

To ensure compatibility of the board between the MC13783VK and the MC13783VK5 parts, follow these steps:

1. If the buck switchers are used in a single configuration, then follow the schematic in [Figure 1](#).
 - a) When SW1 is used in single mode, connect the RSVRD2-SW1ABSPB to VATLAS.
 - b) Connect the SW1AFB on the feedback point at the output capacitor if SW1A is used.
 - c) Connect the SW1BFB on the feedback point at the output capacitor if SW1B is used.
 - d) Perform the same steps for SW2 as performed with SW1.

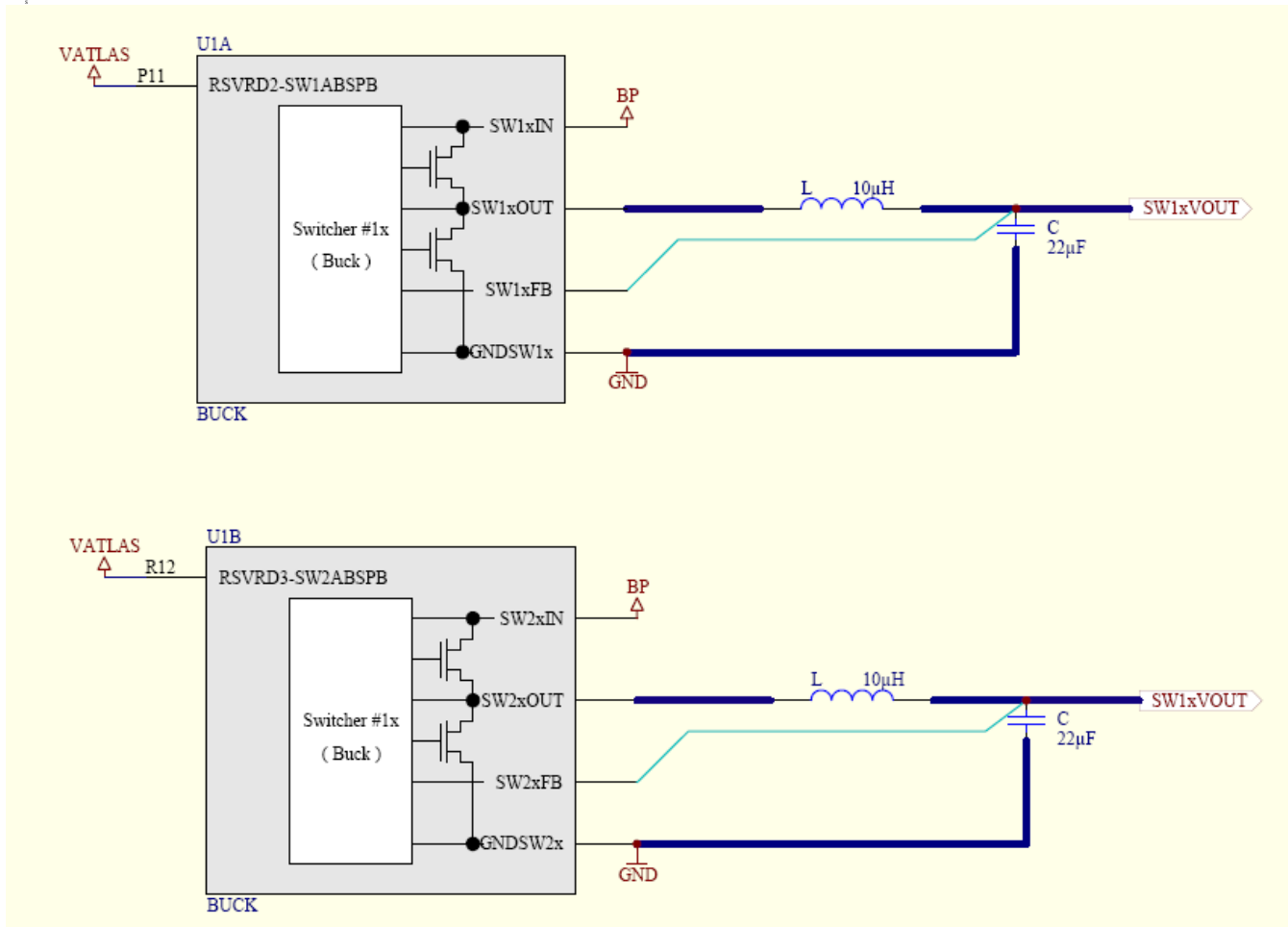

Figure 1. Buck Switchers Used in a Single Configuration

NOTE

On MC13783VK part, the connection of P11 and/or R12 is not mandatory.

2. If the buck switchers are used in a parallel configuration, then follow the schematic in [Figure 2](#).
 - a) The connection to GND of the RSVRDx pin is optional.
 - b) Connect the SWxBFB pin to VATLAS to ensure proper detection for the MC13783VK part. This connection has no effect for the MC13783VK5 part.

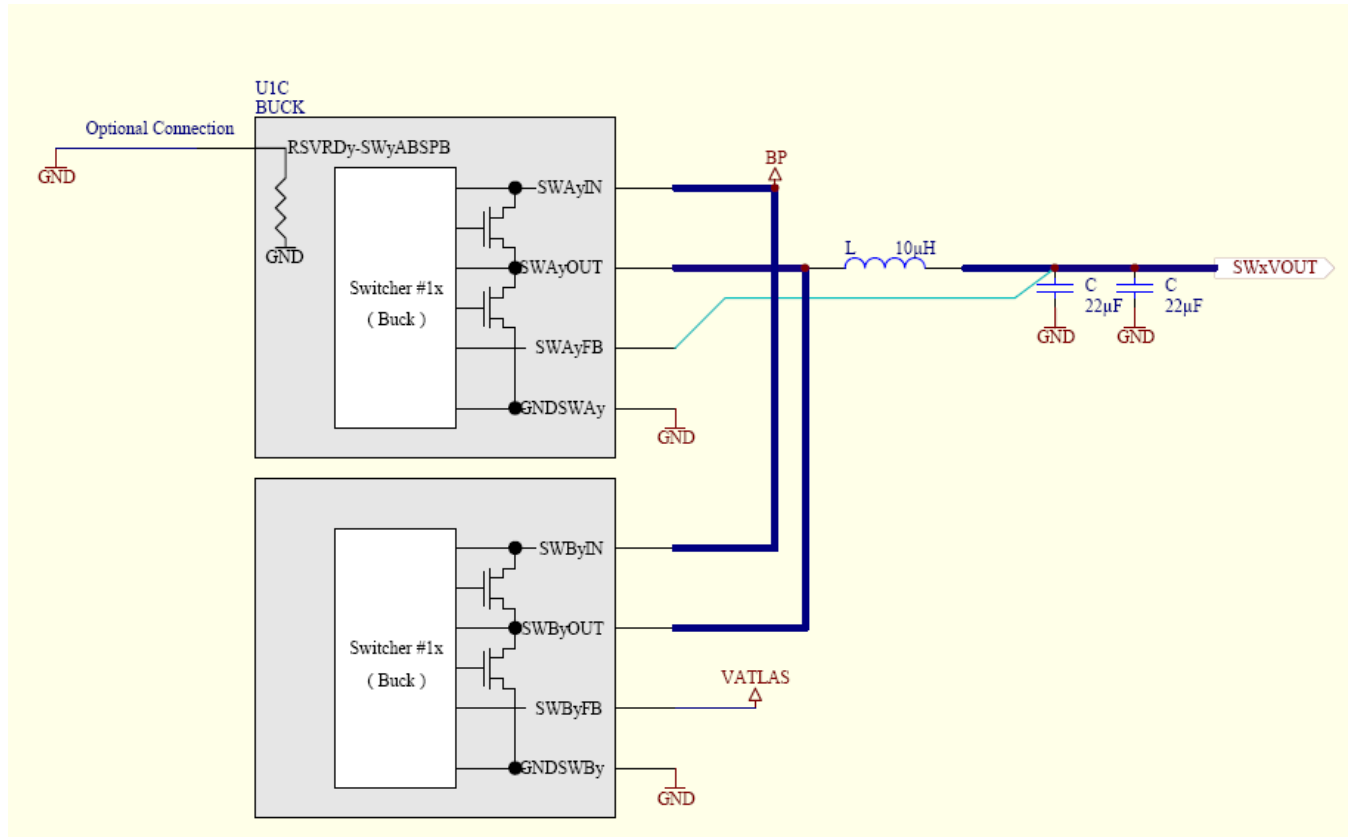

Figure 2. Buck Switchers Used in a Parallel Configuration

NOTE

On P11 and or R12 pin, the GND connection is not mandatory since there is an internal pulldown.

When following these recommended schematic connections, the application is compatible to either the MC13783VK or the MC13783VK5 parts.

NOTES

How to Reach Us:

Home Page:

www.freescale.com

Web Support:

<http://www.freescale.com/support>

USA/Europe or Locations Not Listed:

Freescale Semiconductor, Inc.
Technical Information Center, EL516
2100 East Elliot Road
Tempe, Arizona 85284
1-800-521-6274 or +1-480-768-2130
www.freescale.com/support

Europe, Middle East, and Africa:

Freescale Halbleiter Deutschland GmbH
Technical Information Center
Schatzbogen 7
81829 Muenchen, Germany
+44 1296 380 456 (English)
+46 8 52200080 (English)
+49 89 92103 559 (German)
+33 1 69 35 48 48 (French)
www.freescale.com/support

Japan:

Freescale Semiconductor Japan Ltd.
Headquarters
ARCO Tower 15F
1-8-1, Shimo-Meguro, Meguro-ku,
Tokyo 153-0064
Japan
0120 191014 or +81 3 5437 9125
support.japan@freescale.com

Asia/Pacific:

Freescale Semiconductor China Ltd.
Exchange Building 23F
No. 118 Jianguo Road
Chaoyang District
Beijing 100022
China
+86 10 5879 8000
support.asia@freescale.com

For Literature Requests Only:

Freescale Semiconductor Literature Distribution Center
1-800-441-2447 or +1-303-675-2140
Fax: +1-303-675-2150
LDCForFreescaleSemiconductor@hibbertgroup.com

Information in this document is provided solely to enable system and software implementers to use Freescale Semiconductor products. There are no express or implied copyright licenses granted hereunder to design or fabricate any integrated circuits or integrated circuits based on the information in this document.

Freescale Semiconductor reserves the right to make changes without further notice to any products herein. Freescale Semiconductor makes no warranty, representation or guarantee regarding the suitability of its products for any particular purpose, nor does Freescale Semiconductor assume any liability arising out of the application or use of any product or circuit, and specifically disclaims any and all liability, including without limitation consequential or incidental damages. "Typical" parameters that may be provided in Freescale Semiconductor data sheets and/or specifications can and do vary in different applications and actual performance may vary over time. All operating parameters, including "Typicals", must be validated for each customer application by customer's technical experts. Freescale Semiconductor does not convey any license under its patent rights nor the rights of others. Freescale Semiconductor products are not designed, intended, or authorized for use as components in systems intended for surgical implant into the body, or other applications intended to support or sustain life, or for any other application in which the failure of the Freescale Semiconductor product could create a situation where personal injury or death may occur. Should Buyer purchase or use Freescale Semiconductor products for any such unintended or unauthorized application, Buyer shall indemnify and hold Freescale Semiconductor and its officers, employees, subsidiaries, affiliates, and distributors harmless against all claims, costs, damages, and expenses, and reasonable attorney fees arising out of, directly or indirectly, any claim of personal injury or death associated with such unintended or unauthorized use, even if such claim alleges that Freescale Semiconductor was negligent regarding the design or manufacture of the part.

Freescale™ and the Freescale logo are trademarks of Freescale Semiconductor, Inc. All other product or service names are the property of their respective owners.

© Freescale Semiconductor, Inc. 2006-2010. All rights reserved.