

KIT33662xEFEVBE Evaluation Board

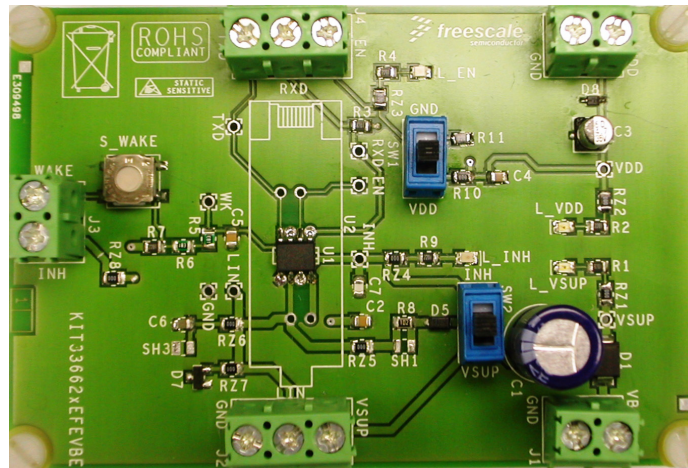

Figure 1. KIT33662xEFEVBE

Table of Contents

1 Kit Contents / Packing List	2
2 Important Notice	3
3 Kit Introduction	4
4 Required Equipment	5
5 KIT33662xEFEVBE Setup Configuration	6
6 KIT33662xEFEVBE Schematic	7
7 Using Hardware	8
8 Board Layout	9
9 Bill of Material	12
10 References	13

1 Kit Contents / Packing List

- KIT33662JEFEVBE or KIT33662LEFEVBE Evaluation Board
- CD MC33662

2 Important Notice

Freescale provides the enclosed product(s) under the following conditions:

This evaluation kit is intended for use of ENGINEERING DEVELOPMENT OR EVALUATION PURPOSES ONLY. It is provided as a sample IC pre-soldered to a printed circuit board to make it easier to access inputs, outputs, and supply terminals. This EVB may be used with any development system or other source of I/O signals by simply connecting it to the host MCU or computer board via off-the-shelf cables. This EVB is not a Reference Design and is not intended to represent a final design recommendation for any particular application. Final device in an application will be heavily dependent on proper printed circuit board layout and heat sinking design as well as attention to supply filtering, transient suppression, and I/O signal quality.

The goods provided may not be complete in terms of required design, marketing, and or manufacturing related protective considerations, including product safety measures typically found in the end product incorporating the goods. Due to the open construction of the product, it is the user's responsibility to take any and all appropriate precautions with regard to electrostatic discharge. In order to minimize risks associated with the customers applications, adequate design and operating safeguards must be provided by the customer to minimize inherent or procedural hazards. For any safety concerns, contact Freescale sales and technical support services.

Should this evaluation kit not meet the specifications indicated in the kit, it may be returned within 30 days from the date of delivery and will be replaced by a new kit.

Freescale reserves the right to make changes without further notice to any products herein. Freescale makes no warranty, representation or guarantee regarding the suitability of its products for any particular purpose, nor does Freescale assume any liability arising out of the application or use of any product or circuit, and specifically disclaims any and all liability, including without limitation consequential or incidental damages. "Typical" parameters can and do vary in different applications and actual performance may vary over time. All operating parameters, including "Typical", must be validated for each customer application by customer's technical experts.

Freescale does not convey any license under its patent rights nor the rights of others. Freescale products are not designed, intended, or authorized for use as components in systems intended for surgical implant into the body, or other applications intended to support or sustain life, or for any other application in which the failure of the Freescale product could create a situation where personal injury or death may occur.

Should the Buyer purchase or use Freescale products for any such unintended or unauthorized application, the Buyer shall indemnify and hold Freescale and its officers, employees, subsidiaries, affiliates, and distributors harmless against all claims, costs, damages, and expenses, and reasonable attorney fees arising out of, directly or indirectly, any claim of personal injury or death associated with such unintended or unauthorized use, even if such claim alleges that Freescale was negligent regarding the design or manufacture of the part. Freescale™ and the Freescale logo are trademarks of Freescale Semiconductor, Inc. All other product or service names are the property of their respective owners. © Freescale Semiconductor, Inc. 2011

3 Kit Introduction

This Evaluation Board is supplied for preliminary evaluation purposes. This kit is populated with a production device, and gives to you the opportunity to test the device in various configuration cases to quickly evaluate these features. This kit can also be used for Electro Static Discharge (ESD) and Bulk Current Injection (BCI) tests.

3.1 Evaluation Board Features

- Individually routed power supply inputs for VDD and VBAT
- Status of product indicated by an LED
- Slave or master configuration via a switch
- Wake button
- Mode selector via a switch
- Test point for every pin

3.2 Device Description/Features

- Operational from a V_{SUP} of 7.0 to 18 V DC, functional up to 27 V DC, and handles 40 V during Load Dump
- Compatible with LIN Protocol Specification 1.3, 2.0, 2.1, and SAEJ2602-2
- Active bus wave shaping, offering excellent radiated emission performance
- Sustains up to 15.0 kV minimum ESD IEC61000-4-2 on the LIN Bus, WAKE, and VSUP pins
- Very high immunity against electromagnetic interference
- Low standby current in Sleep mode
- Over-temperature protection
- Local and remote wake-up capability reported by the RXD pin
- Fast baud rate mode selection reported by RXD
- 5.0 and 3.3 V compatible digital inputs without any required external components

4 Required Equipment

To use this kit you need:

- +12 VDC power supply
- +5.0 VDC power supply
- 0/+5.0 V waveform generator

5 KIT33662xEFEVBE Setup Configuration

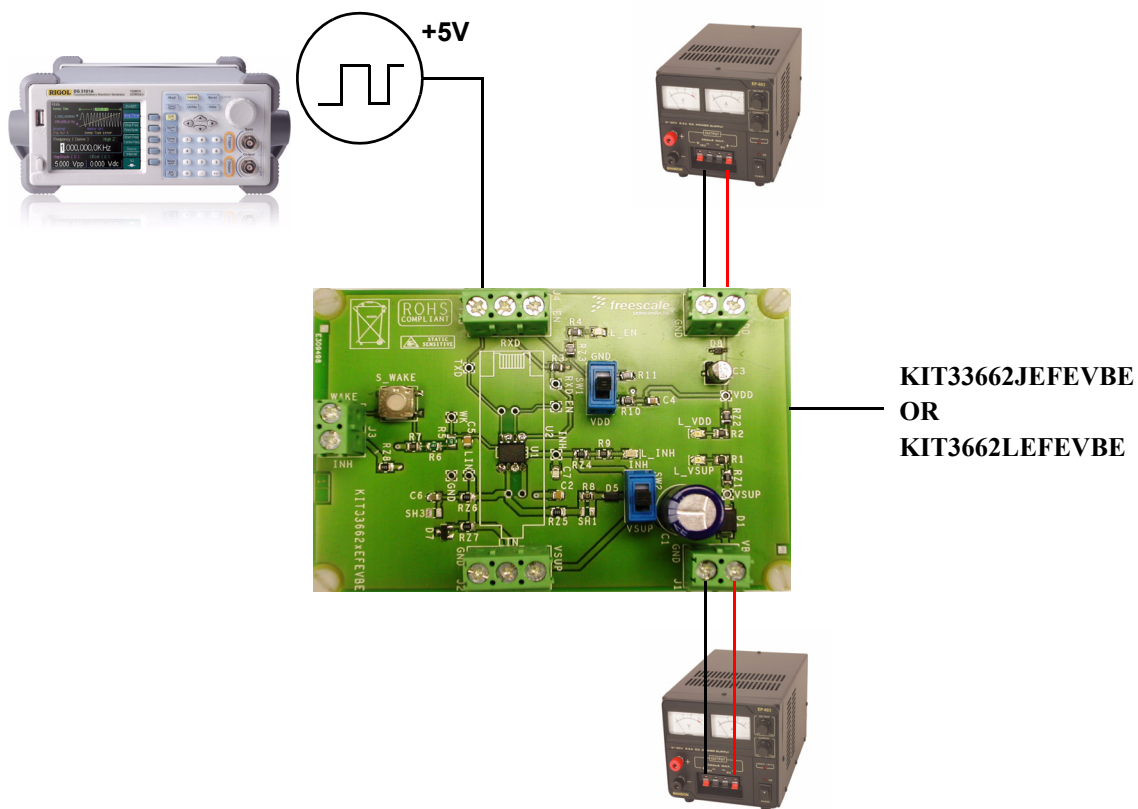

Figure 1. KIT33662xEFEVBE Setup Configuration Diagram

6 KIT33662xEFEVBE Schematic

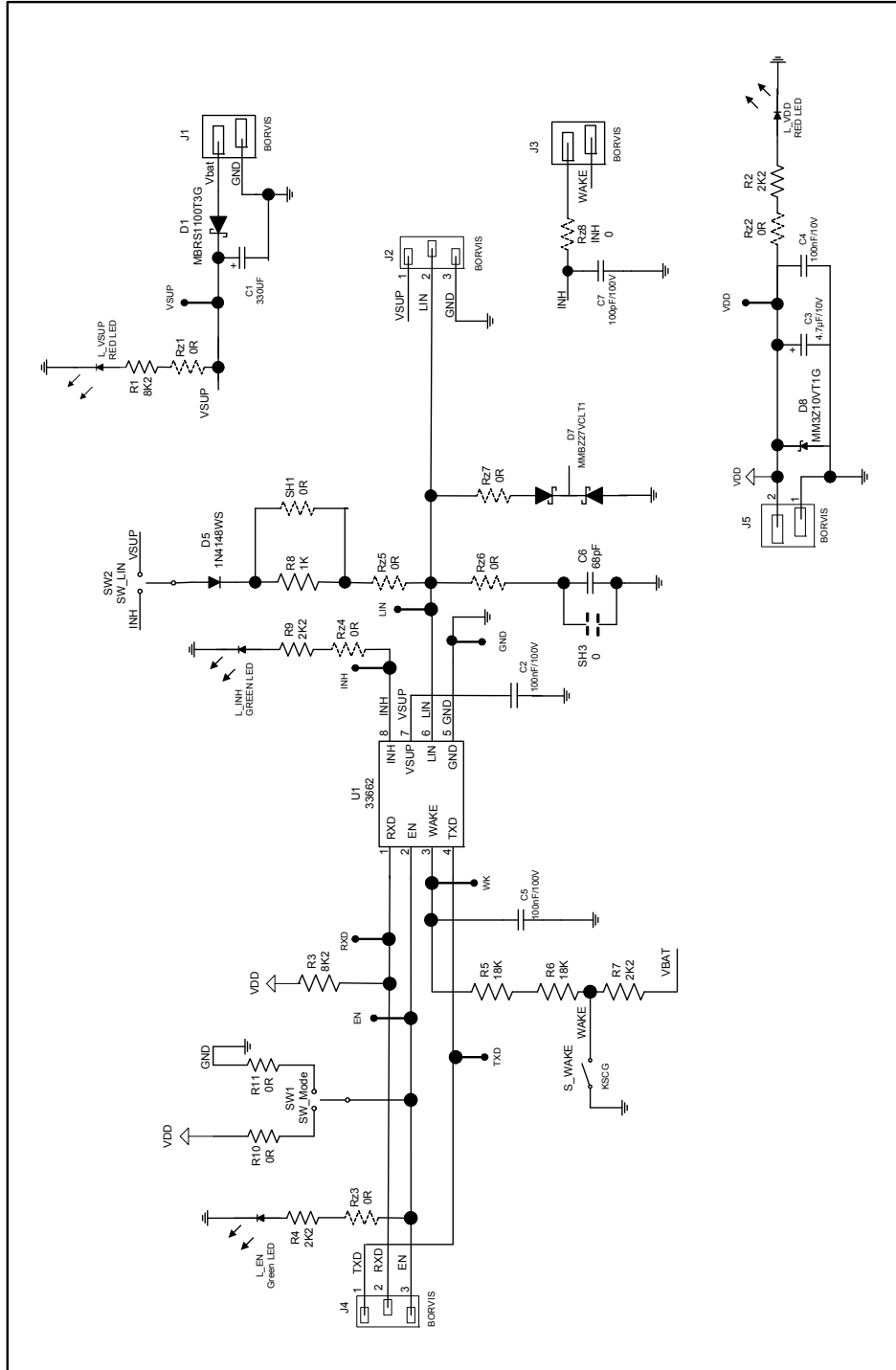

Figure 2. KIT33662xEFEVBE Schematic

7 Using Hardware

7.1 Jumper Connections

RZ1	LED for VSUP state
RZ2	LED for VDD state
RZ3	LED for EN state
RZ4	LED for INH state
RZ5	enable SW2
RZ6	add C6 on LIN bus
RZ7	add D7 on LIN bus
RZ8	can be change to add load on INH BUS
R10	can be change to limit current on EN pin ⁽¹⁾
R11	can be change to limit current on EN pin ⁽¹⁾
SW1	connect EN pin to: <ul style="list-style-type: none"> • VDD (1) • EN connector (2) • GND (3)
SW2	add load on LIN bus and set Master/slave configuration: <ul style="list-style-type: none"> • connected to VSUP (1)(Master configuration 1) • unconnected (2)(Slave configuration) • INH (3)(Master Configuration 2)
SW3	connect the WAKE pin to GND
SH1	slot to change the load value on LIN bus
SH3	slot to change the load value on LIN bus

Note:

1. In this case, RZ3 must be unsoldered to have 5.0 V on the EN pin

8 Board Layout

8.1 Assembly Top Layer

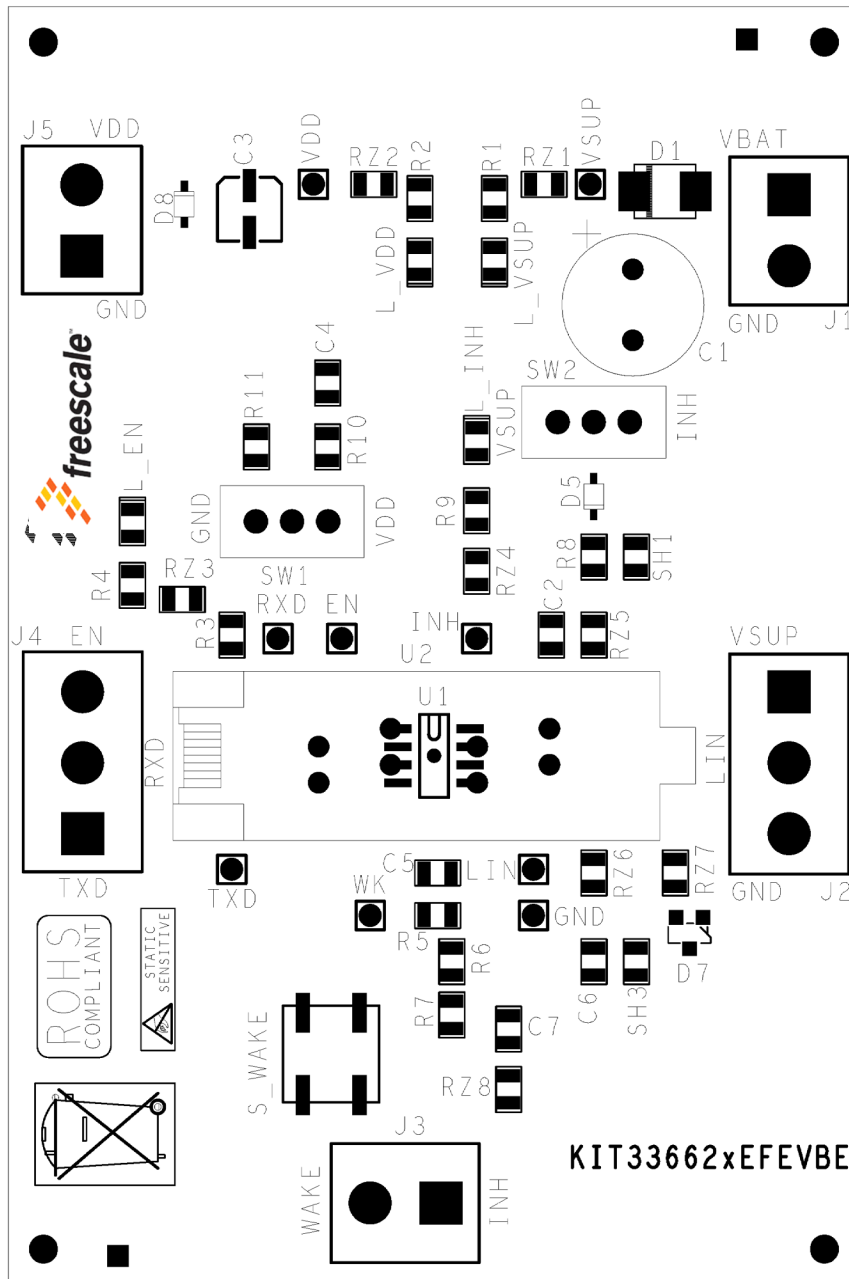

Figure 3. Assembly Top Layer

8.2 Top Layer Routing

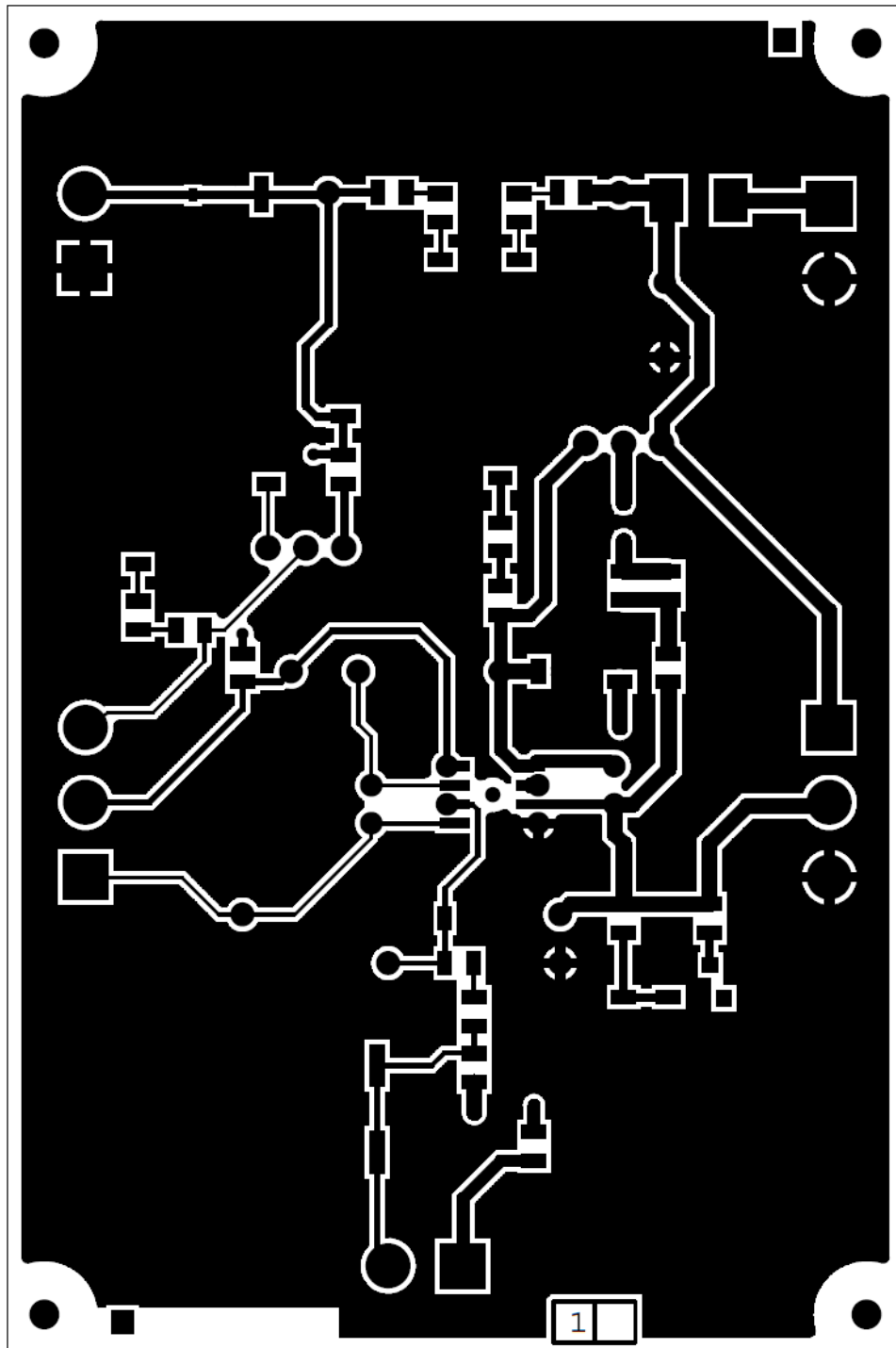

Figure 4. Top Layer Routing

8.3 Bottom Layer Routing

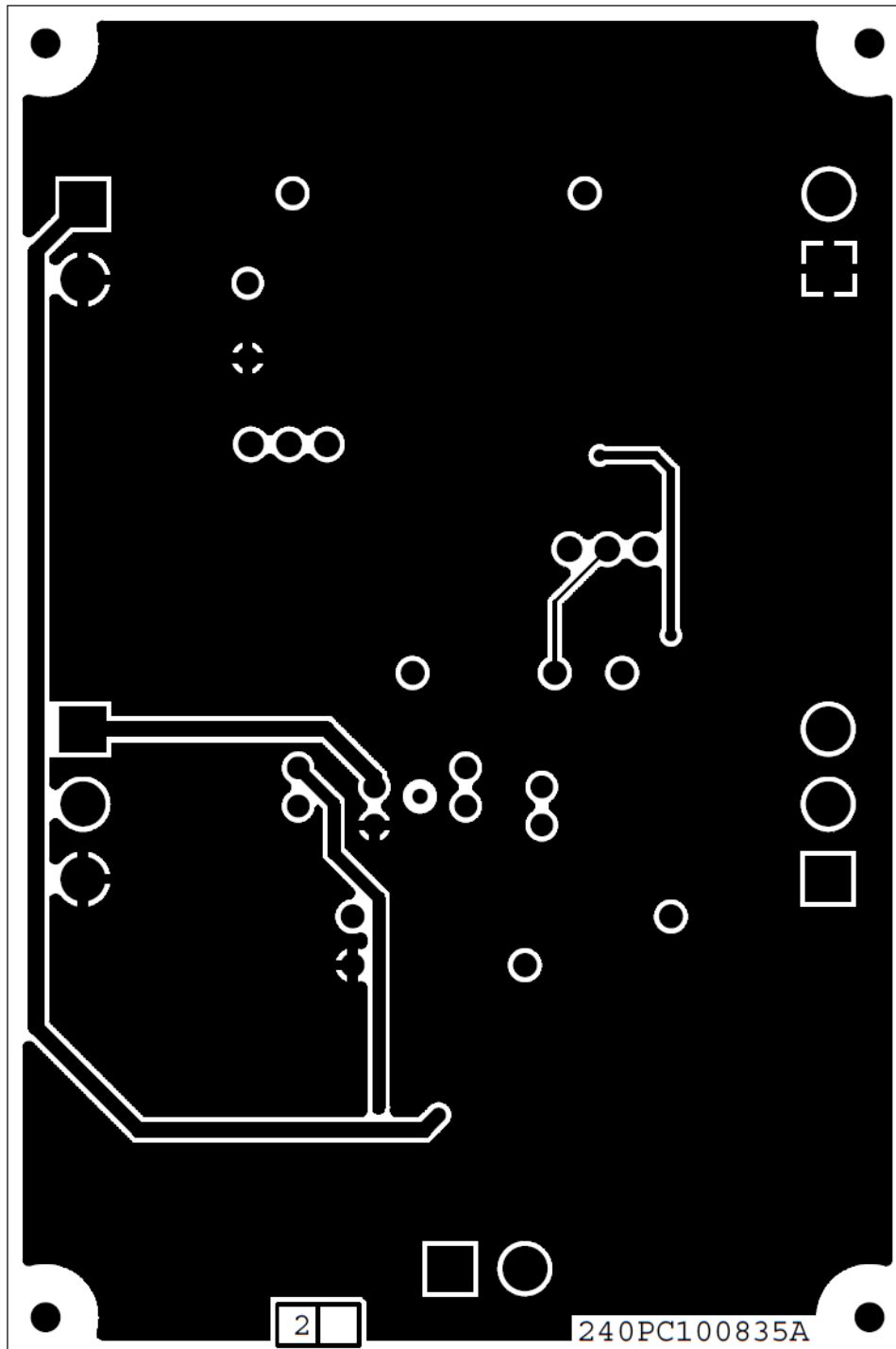

Figure 5. Bottom Layer Routing

9 Bill of Material

Table 1. KIT33662xEFEVBE Bill of Material ⁽²⁾

Quantity	Part Reference	Device or Value	Description
Freescall Components			
1	U1	MC33662JEF or MC33662LEF	10kbps baud rate 20kbps baud rate
1	U2	Socket	SOIC8 socket - LIN Transceiver
Capacitors			
1	C1	330 μ F/100 V	CAP ALEL 20% - RADIAL
2	C2, C5	100 nF/100 V	CAP CER 10% - X7R 0805
1	C3	4.7 μ F/10 V	CAP ALEL 20% - RADIAL
1	C4	100 nF/10 V	CAP CER 10% - X7R 0805
1	C6	68 pF/100 V	CAP CER 10% - X7R 0805
1	C7	100 pF/100 V	CAP CER 10% - X7R 0805
Resistors			
2	R1, R3	8.2 K	RES TF 1/8 W 5% - RC0805
4	R2, R4, R7, R9	2.2 K	RES TF 1/8 W 1% - RC0805
2	R5, R6	18 k	RES TF 1/8 W 1% - RC0805
	R8	1.0 K	RES TF 1/8 W 5%
2	R10, R11	0	RES 0 - RC0805
8	RZ1, RZ2, RZ3, RZ4, RZ5, RZ6, RZ7, RZ8	0	RES 0 - RC0805
Diode			
1	D1	MBRS1100T3G	Schottky 1.0 A 100 V - SMB
1	D5	1N4148WS	DIODE 150 mA 53 V - SOD-323
1	D7	MMBZ27VCLT1	Dual Common Cathode Zeners - SOT-23
1	D8	MM3Z10VT1G	Zener 10 V 5% 200 mW - SOD-323
2	L_INH, L_EN	LXT0805GW	LED GREEN 20MA
2	L_VDD, L_VSUP	LXT0805RW	LED RED 20MA
Connectors			
3	J1, J3, J5	PCB 2WAY 250 V/16 A	CON 2
2	J2, J4	PCB 3WAY 250 V/16 A	CON 3
2	SW1, SW2	TG39P0 20 V/0.4 A	SPDT ON-OFF-ON
1	S-WAKE	KSC221J 32 V/50 mA	SW SPST SMT

Note:

- Freescall does not assume liability, endorse, or warrant components from external manufacturers that are referenced in circuit drawings or tables. While Freescall offers component recommendations in this configuration, it is the customer's responsibility to validate their application

10 References

Following are locations where you can obtain information on other Freescale products and application solutions.

Description	URL
Reference Web Sites	Reference URL Locations
MC33662 Data Sheet	http://www.freescale.com/files/analog/doc/data_sheet/MC33662.pdf
Application Notes	http://www.freescale.com/files/analog/doc/app_note/AN2409.pdf
Freescale's Web Site	http://www.freescale.com
Freescale's Analog and Power Management Web site	http://www.freescale.com/analog
Freescale's Automotive Applications Web site	http://www.freescale.com/automotive

How to Reach Us:

Home Page:

www.freescale.com

Web Support:

<http://www.freescale.com/support>

USA/Europe or Locations Not Listed:

Freescale Semiconductor, Inc.
 Technical Information Center, EL516
 2100 East Elliot Road
 Tempe, Arizona 85284
 1-800-521-6274 or +1-480-768-2130
www.freescale.com/support

Europe, Middle East, and Africa:

Freescale Halbleiter Deutschland GmbH
 Technical Information Center
 Schatzbogen 7
 81829 Muenchen, Germany
 +44 1296 380 456 (English)
 +46 8 52200080 (English)
 +49 89 92103 559 (German)
 +33 1 69 35 48 48 (French)
www.freescale.com/support

Japan:

Freescale Semiconductor Japan Ltd.
 Headquarters
 ARCO Tower 15F
 1-8-1, Shimo-Meguro, Meguro-ku,
 Tokyo 153-0064
 Japan
 0120 191014 or +81 3 5437 9125
support.japan@freescale.com

Asia/Pacific:

Freescale Semiconductor China Ltd.
 Exchange Building 23F
 No. 118 Jianguo Road
 Chaoyang District
 Beijing 100022
 China
 +86 10 5879 8000
support.asia@freescale.com

For Literature Requests Only:

Freescale Semiconductor Literature Distribution Center
 P.O. Box 5405
 Denver, Colorado 80217
 1-800-441-2447 or +1-303-675-2140
 Fax: +1-303-675-2150
LDCForFreescaleSemiconductor@hibbertgroup.com

Information in this document is provided solely to enable system and software implementers to use Freescale Semiconductor products. There are no express or implied copyright licenses granted hereunder to design or fabricate any integrated circuits or integrated circuits based on the information in this document.

Freescale Semiconductor reserves the right to make changes without further to products herein. Freescale Semiconductor makes no warranty, representation or regarding the suitability of its products for any particular purpose, nor does Freescale Semiconductor assume any liability arising out of the or use of any product or circuit, and specifically disclaims any and all liability, including without limitation consequential or incidental damages. "Typical" parameters that may be provided in Freescale Semiconductor data sheets and/or specifications can and do vary in different applications and actual performance may vary over time. All operating parameters, including "Typicals", be validated for each customer application by technical experts. Freescale Semiconductor does not convey any license under its patent rights nor the rights of others. Freescale Semiconductor products are designed, intended, or authorized for use as components in systems intended for surgical implant into the body, or other applications intended to support or sustain life, or for any other application in which the failure of the Freescale Semiconductor product could create a situation where personal injury or death may occur. Should Buyer purchase or use Freescale Semiconductor products for any such unintended or unauthorized application, Buyer shall indemnify and hold Freescale Semiconductor and its officers, employees, subsidiaries, affiliates, and harmless against all claims, costs, damages, and expenses, and reasonable attorney fees arising out of, directly or indirectly, any claim of personal injury or death associated with such unintended or unauthorized use, even if such claim alleges that Freescale Semiconductor was negligent regarding the design or manufacture of the part.



Freescale and the Freescale logo are trademarks of Freescale Semiconductor, Inc., Reg. U.S. Pat. & Tm. Off. Qorivva, S12 MagniV, SMARTMOS and Xtrinsic are trademarks of Freescale Semiconductor, Inc. ARM is the registered trademark of ARM Limited. The Power Architecture and Power.org word marks and the Power and Power.org logos and related marks are trademarks and service marks licensed by Power.org. All other product or service names are the property of their respective owners. ©2011 Freescale Semiconductor, Inc.